

Instrument Cluster

The instrument cluster is new and cannot be installed in older models. The most important changes include a new printed circuit and printed circuit carrier, which now has 17-pin plug connections horizontally (was 14 pins / vertically).

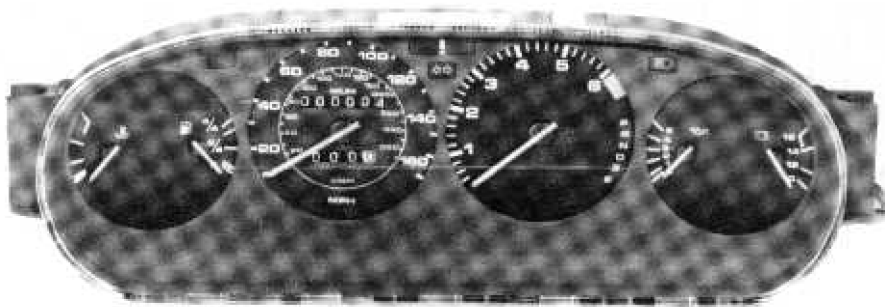

In cars with automatic transmission there is an additional 6-pin plug connection coming out of the instrument cluster, which is connected with the rear wire harness via the starting interlock switch and is used for display of the selector lever position in the tachometer. The entire displaying electronics is integrated in the instrument cluster.

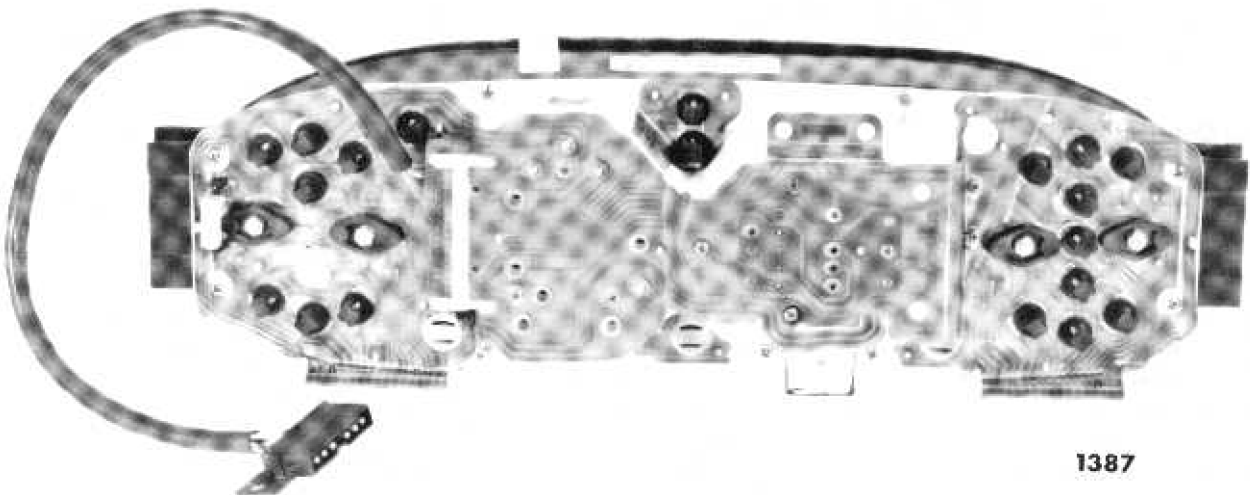

1387

ELECTRICAL SYSTEM – Instruments

Wiring Diagram:

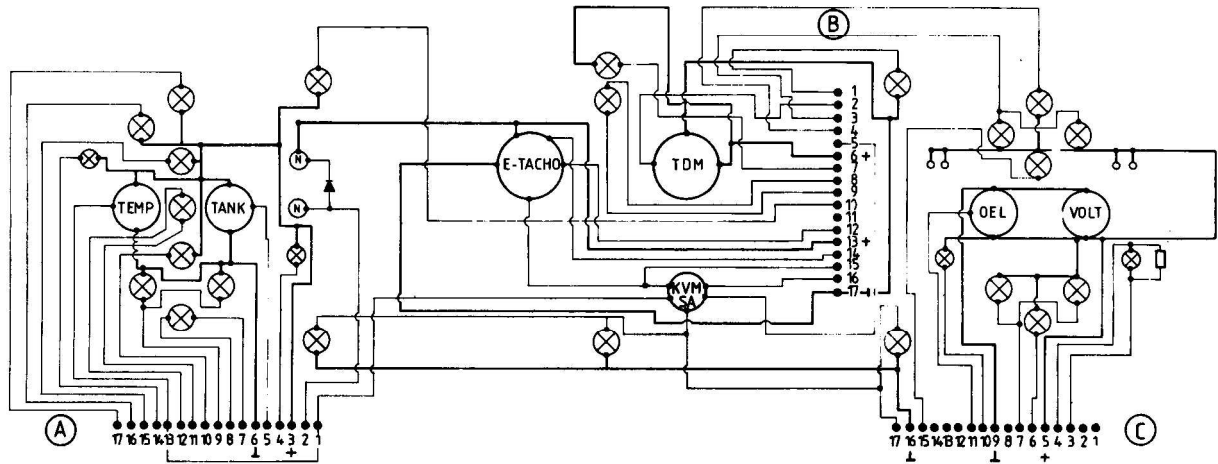

Plug Connections

Wiring Diagram for Range Indicator (Automatics)

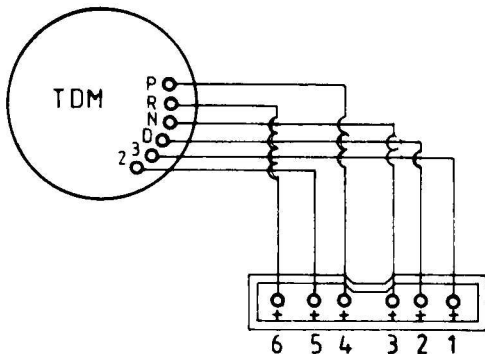

Plug Connections

Recep.	Gear	Wire Colors
1	3	white
2	D	black
3	N	yellow
4	P	green
5	2	red
6	R	gray / yellow

Plug Connections

A	B	C
1 Temp. transm. (ground)	+ High beams	+ Battery charge
2 - Neutral position	TDM transm.	- Battery charge
3 + Term. 15 pos. general	- Brake fluid	+ Term. 15 pos. general
4 - Fuel warning	- ABS	- Oil level
5 Fuel level transm.	KVM transm.	- Parking brake
6 - Term. 31 grd. general	+ Term. 15 pos. general	- Term. 31 grd. general
7 + Coolant	- Central warning	- Oil warning
8 - Coolant	+ Turn signals	Oil press. transm.
9 + Side marker lights	- Turn signals	
10 - Washing fluid	- EX	
11 + Trailer turn signals	Buzzer outlet (Japan/Arabia)	
12 - Trailer turn signals	+ Term. 15 pos. general	
13 + Temp. transmitter	Speedometer	
14 - Temp. warning	Digital speedometer	
15 - Stop lights	+ Term. 30	- Brake pads
16 - Tail lights	- Term. 31 grd. general	- Term. 31 grd. general
17 - Drive belt tightness		+ Term. 58d inside lights

ELECTRICAL SYSTEM – Instruments

Instrument Cluster Survey

	Porsche Number	Version	Country	Contr. Lamp	Engine Electr.	EC Scale	Upsh. Ind.	Range Ind.	Ignition System
1	928.641.103.35	German	Germany		LH-Jetr.	L/100 km			EZF
2	928.641.106.35	German	Austria / Switzerland		LH-Jetr.				EZF
3	928.641.104.35	French	France		LH-Jetr.				EZF
4	928.641.117.35	English	Saudi-Arabia (speed warning)		LH-Jetr.				EZF
5	928.641.124.00	English	R. o. W. / Canada		LH-Jetr.			•	EZF
6	928.641.116.35	English	England (double scale)		LH-Jetr.				EZF
7	928.641.102.35	English	USA (double scale)		LH-Jetr.		•		EZF
8	928.641.133.00	German	Germany		LH-Jetr.	L/100 km		•	EZF
9	928.641.136.00	German	Austria / Switzerland		LH-Jetr.			•	EZF
10	928.641.134.00	French	France		LH-Jetr.			•	EZF
11	928.641.127.00	English	Japan (speed warning)	EX	LH-Jetr.				EZF
12	928.641.137.00	English	Saudi-Arabia (speed warning)		LH-Jetr.			•	EZF
13	928.641.126.00	English	England / USA (double scale)		LH-Jetr.			•	EZF
14	928.641.109.35	English	R. o. W. / Canada		LH-Jetr.				EZF